

# **AUSTIN** *1/2 Ton Van & Pick-Up*

*Two new and practical all-steel  
vehicles designed to carry loads of up  
to 1/2 ton with the utmost economy*



# AUSTIN 1/2 TON PICK-UP

*Sturdily built for use in town or country*

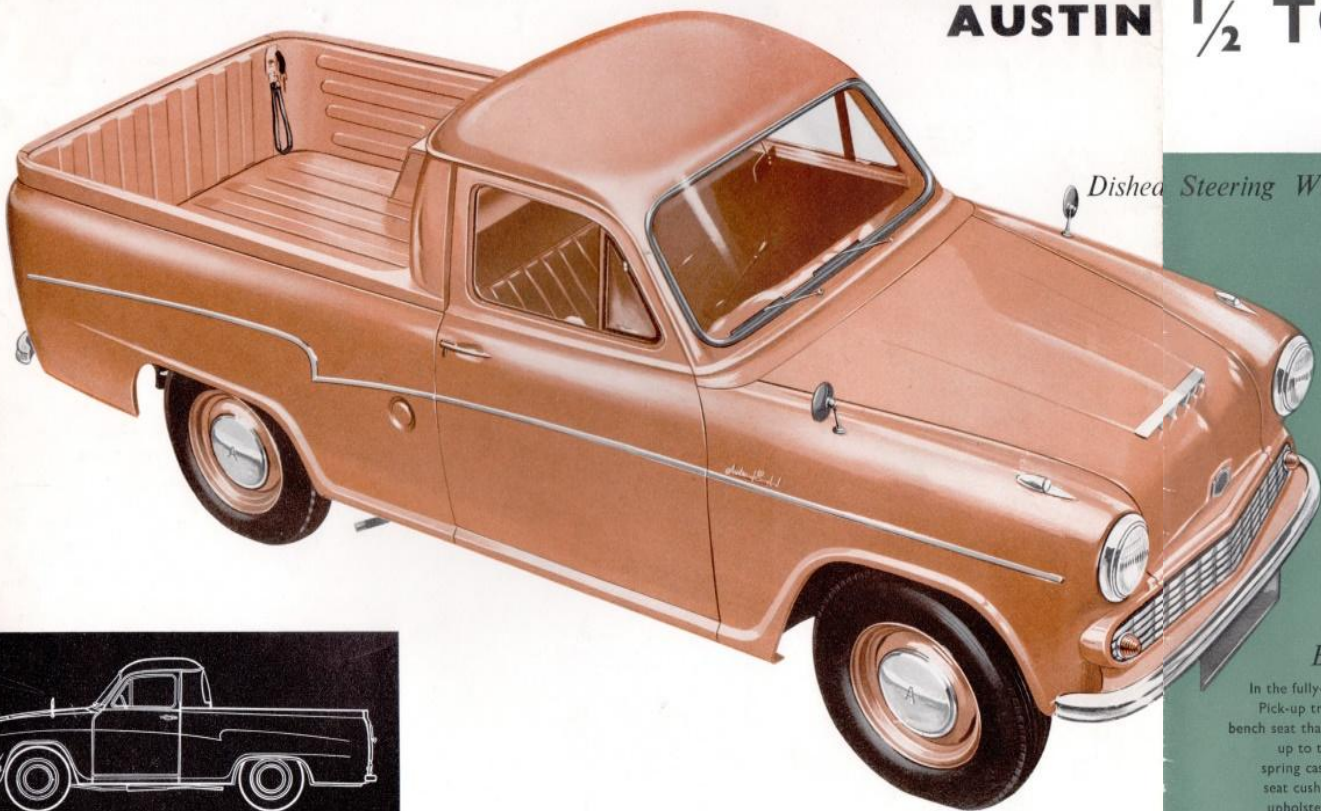

*Dished Steering Wheel*



The driver will appreciate the safety factor in the design of this two-spoke dished steering wheel. It is 17 inches in diameter and affords an exceedingly comfortable grip.

*Bench Seat*

In the fully-enclosed cab of the Pick-up truck is an adjustable bench seat that will accommodate up to three persons. The spring cases of the squab and seat cushion are comfortably upholstered and trimmed in hard-wearing vinyl-treated fabric.

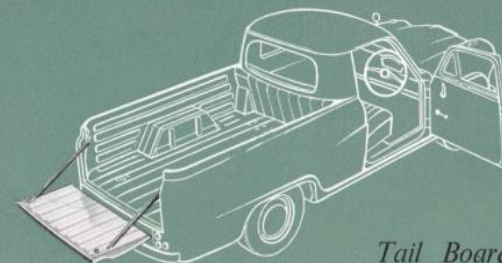
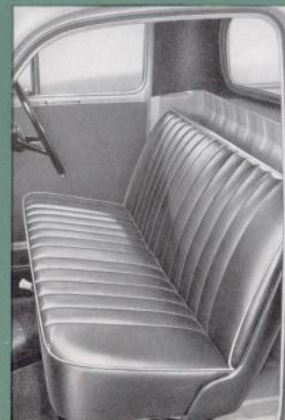

*Tail Board*

The double steel panels of the rear tail board ensure a strong, rigid platform that can be held in the horizontal position by a pair of stout anchor chains. Captive chained pegs secure it in the upright position.

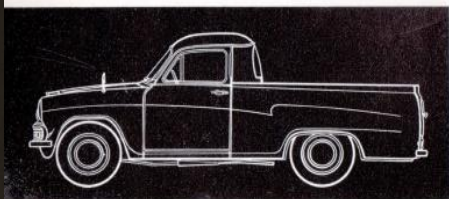

### Cab Interior

Car-type comfort is provided for the driver of the Austin  $\frac{1}{2}$ -ton Van. Controls are conveniently positioned in relation to the adjustable driving seat, thereby minimising driving fatigue. Provision is made for installing, at extra cost, such items as radio, electric clock, heater/demister and adjustable passenger seat.



### Van Interior

Loading height of the interior is ideal at 2 ft. 2 ins. The steel floor is corrugated to facilitate easy loading, and the wheel boxes are flat-topped, to cause as little inconvenience as possible. A passenger seat can be fitted if desired, otherwise the body interior can be reached from the driving compartment.



### Fascia

The design of the fascia in the Austin  $\frac{1}{2}$ -ton vehicles is neat and straightforward, all controls being located near to hand. Immediately in front of the driver is the speedometer, which also incorporates the fuel gauge, water temperature indicator and warning lights to show low oil pressure, no dynamo charge and headlamp high beam position. A closed compartment is also included on the opposite side of the fascia for such items as log books and time sheets.



### Hydraulic Brakes

Large-diameter hydraulic brakes on all wheels respond to the lightest pressure. Front brakes are of two-leading-shoe design.

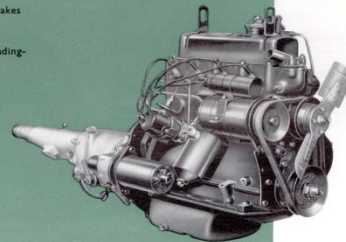

### O.H.V. Power

The 1489 c.c. engine used in the Austin  $\frac{1}{2}$ -ton vehicles is a compact O.H.V. design producing an output of 47 B.H.P. at 4,100 r.p.m. With a compression ratio of 7.2 to 1 it is extremely efficient when using commercial grade fuel. The four-speed gearbox is fitted with synchromesh engagement on 2nd, 3rd and top speeds and is operated by a gear change lever on the steering column.

## AUSTIN $\frac{1}{2}$ TON VAN

Distinctive and economical . . . with 110 cubic feet of loadspace

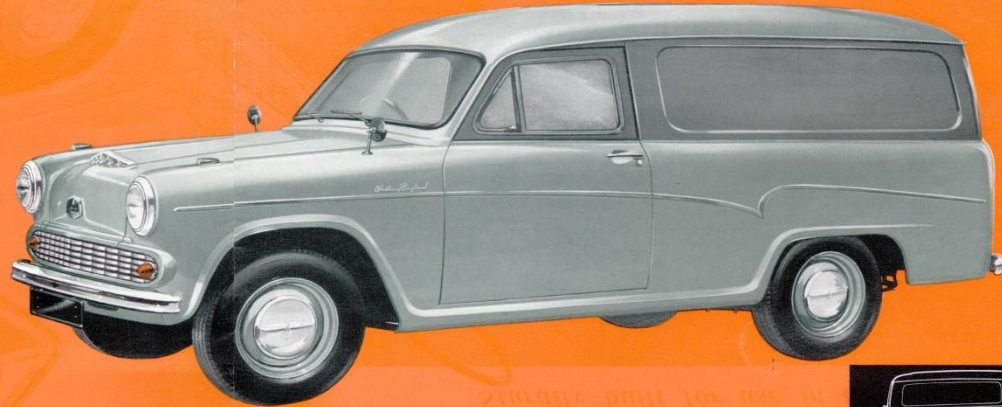

Here is another model in the Austin  $\frac{1}{2}$ -ton commercial vehicle range—a new delivery van, designed and built to stand up to the rigours of daily delivery work. And not just a "goods vehicle"—or though it is primarily for commercial use, this new  $\frac{1}{2}$ -ton van will preserve the dignity of any business with its smart, distinctive appearance.

It is of all-steel unitary construction, having one-piece steel roof and body sides with large-area impressed panels suitable for display.

All windows are of toughened glass, and the wide curved windscreen is

fitted with dual self-parking wipers, which clean a large central area. There is provision for fitting safety harness.

Opening of the rear doors is restricted to 90°, and they can be held in the open position by spring-loaded checks incorporated in the concealed hinges. Side- and rear-doors are lockable and sealed against the entry of dust and draught.

Everything about this van has been designed to minimise maintenance and provide easy operation, so necessary to the tradesman who wishes to give quick and profitable service.

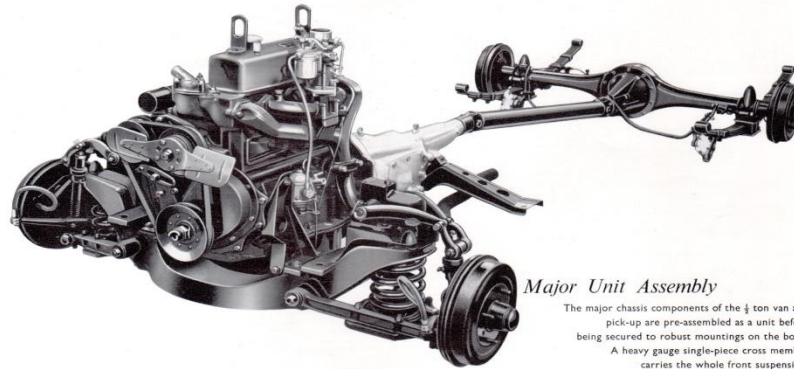

### Major Unit Assembly

The major chassis components of the  $\frac{1}{2}$ -ton van and pick-up are pre-assembled as a unit before being secured to robust mountings on the body. A heavy gauge single-piece cross member carries the whole front suspension.

# S P E C I F I C A T I O N S

**ENGINE :** In-line, water cooled, four-cylinder, O.H.V.; bore 2.875 in. (73.025 mm.); stroke 3.5 in. (89.0 mm.); cubic capacity 1489 c.c. (90.88 cu. in.); maximum b.h.p. 47 at 4,100 r.p.m.; maximum torque 74 lb. ft. at 2,100 r.p.m.; compression ratio 7.2 to 1.

**Fuel System :** Zenith downdraught carburettor; A.C. mechanical fuel pump; oil wetted air cleaner (oil bath for Export); tank capacity approximately 8½ gallons (37.5 litres).

**Lubrication System :** Full pressure with wet sump; gear type pump driven from camshaft; full-flow external oil filter, and gauze in sump; sump capacity approximately 6½ pints (3.84 litres) plus 1½ pints (0.71 litres) for full-flow filter.

**Ignition System :** Coil and distributor with auto vacuum control.

**Cooling System :** Pressurised radiator with fan, pump and thermostat; capacity approximately 12 pints (6.8 litres).

**CHASSIS : Transmission :** Single dry plate clutch, 8 in. (0.20 m.) diameter. Gearbox ratios: first 3.945, second 2.403, third, 1.490, top 1.000, reverse 5.159; remote control gear lever on steering column; Gearbox oil capacity approximately 4½ pints (2.70 litres); open propeller shaft with needle roller bearing universal joints; rear axle ratio 4.875 to 1 (8/39); rear axle oil capacity approximately 2 pints (1.14 litres). Road speeds at 1,000 r.p.m.: first 3.80 m.p.h., second 6.25 m.p.h., third 10.07 m.p.h., top 15.01 m.p.h.

**Steering :** Cam and peg; ratio 15 to 1; two-spoked, 17 in. (0.43 m.) diameter dished steering wheel.

**Suspension :** Front—Independent, with wishbones, coil springs and shock absorbers; rear—semi-elliptic leaf springs with shock absorbers and stabilizing bar. Hydraulic lever type shock-absorbers.

**Brakes :** Girling hydraulic, two-leading-shoe at front; 9 in. diameter x 1½ in. wide.

**Road Wheels :** Pressed steel, four-nut fixing, with 6.40—14 heavy duty tubeless tyres.

**ELECTRICAL :** 12-volt battery of 43 amp hour capacity (57 amp. hour for cold countries); built-in headlamps with double filament bulbs for dipping; foot-operated dipswitch; separate sidelamps mounted on wings, visible to driver; twin stop-tail lamps; rear number plate lamp and twin reflectors; flashing direction indicators operated by self-cancelling lever with built-in warning light; single horn; dual windscreen wipers.

The issue of this publication does not constitute an offer, and the right is reserved to alter prices and/or specifications at any time without notice. Sales are made subject to and with the benefit of the Austin Motor Co. Ltd. or Austin Motor Export Corporation Ltd. Conditions of Sale and Warranty, copies of which are available from Distributors and Dealers. For prices see separate lists.

**INSTRUMENTS :** Trip and total mileage speedometer which also incorporates the fuel gauge, water temperature indicator, and warning lights to indicate low oil pressure, no dynamo charge and headlamp high beam position.

**COACHWORK—Van :** An all-steel vehicle of unitary construction for carrying loads, in addition to the driver, of up to ½ ton. The load floor is steel-lined and corrugated to facilitate easy loading and the wheel boxes are flat-topped. Large impressed panels in the body sides are suitable for sign-writing. Each rear door has a large window and opens to 90°, where it is retained by a spring catch incorporated in the concealed hinges. One of the double doors is fitted with bolt catches at top and bottom edges. Adjustable driver's seat trimmed with vinyl-treated fabric. Passenger seat (Export only). Vinyl-treated fabric roof lining. One sun visor. A closed compartment is provided in fascia and full width parcel shelf runs beneath. Front doors are dust- and draught-proof, fitted with locks, friction-controlled ventilating louvres and wind-down windows. All windows and the wide curved windscreen are of toughened glass. The bonnet lock is controlled from inside the van. The cab floor is covered with a rubber mat. Anodised aluminium front grille incorporating front flashers. Bright moulding attached to body side panels. Twin wing-mounted rear view mirrors. Spare wheel carried in wind-down tray beneath the floor at the rear of the vehicle, operated by starting handle. Bumpers fitted front and rear. Petrol filler on right-hand side. Availability: Left- or right-hand steering; m.p.h. or km.p.h. speedometer; complete van; chassis front-end comprising bonnet assembly, fascia, seat, screen and pillars (no doors).

**Pick-up Truck :** Two-door, two-seater vehicle of all-steel unitary construction, with fully-enclosed cab, for carrying loads of up to ½ ton in addition to the driver. Curved windscreen and backlight, toughened glass windows all round. Adjustable bench-type seat covered in vinyl-treated fabric. Doors, hinged on forward edges, are fitted with wind-down windows and swivelling ventilating louvres. Each door is lockable and sealed against the entry of dust or draught. A closed compartment is provided on the passenger side of fascia and full-width parcel shelf runs beneath. Bonnet lock controlled from inside vehicle. Vinyl-treated fabric roof lining. Cab floor covered with rubber mat. Anodised aluminium front grille, incorporating front flashers. Bright moulding attached to body side panels. Twin wing-mounted rear view mirrors. Spare wheel carried in wind-down tray beneath floor at rear of vehicle, operated by starting handle. Bumpers fitted front and rear. One sun visor. Petrol filler at right-hand side. The body has steel inner and outer panels and the wheel boxes are flat-topped. The floor is of strongly swaged steel and the double panelled tailboard is held in the horizontal position by chains. Availability: Left- or right-hand steering; m.p.h. or km.p.h. speedometer; complete pick-up; chassis-cab.

**OPTIONAL EXTRAS :** Passenger seat on van; heater and demister; (laminated windscreen and passenger's sun visor, Export only).

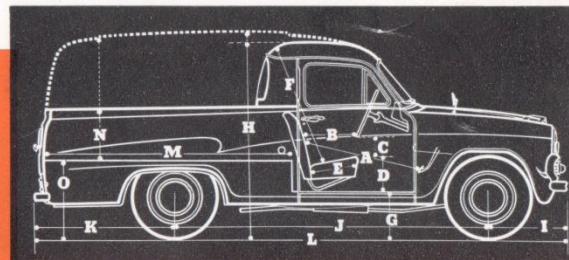

LEADING DIMENSIONS	½-ton VAN		½-ton PICK-UP	
	ft. ins.	metric	ft. ins.	metric
Pedal to seat squab ... A	3 2	0.97 m.	3 2½	0.98 m.
Steering wheel to seat squab B	2 11½	0.90 m.	2 9½	0.84 m.
	1 3½	0.40 m.	1 2½	0.37 m.
Steering wheel to seat cushion ... C	1 1½	0.33 m.	11	0.28 m.
	5½	0.14 m.	4½	0.12 m.
Front seat cushion above floor ... D	1 2½	0.37 m.	1 3½	0.38 m.
Front seat cushion depth ... E	1 5½	0.44 m.	1 6	0.46 m.
Head room over front seat ... F	3 3	0.99 m.	3 1½	0.95 m.
Cab floor to ground ... G	1 1½	0.34 m.	1 1½	0.34 m.
Overall height (unladen) ... H	5 7½	1.72 m.	5 2½	1.58 m.
Centre front wheel to bumper ... I	2 1½	0.64 m.	2 1½	0.64 m.
Wheelbase ... J	8 3½	2.52 m.	8 3½	2.52 m.
Centre rear wheel to bumper ... K	3 8½	1.13 m.	3 8½	1.13 m.
Overall length ... L	14 0½	4.29 m.	14 0½	4.29 m.
Length of body floor ... M	6 6½	2.01 m.	6 3½	1.91 m.
Max. interior height ... N	3 7½	1.10 m.	1 7½	0.49 m.
Body floor to ground ... O	2 2	0.66 m.	2 2½	0.67 m.
Height of rear door opening ... P	2 11½	0.90 m.	1 7½	0.49 m.
Overall width ... Q	5 2½	1.59 m.	5 2½	1.59 m.
Seat cushion width ... R	1 7	0.48 m.	4 3½	1.31 m.
Width between wheel arches ... S	3 2	0.97 m.	3 2	0.97 m.
Width of rear door opening ...	3 7½	1.11 m.	3 7½	1.11 m.
Body interior width ...	5 0½	1.54 m.	4 7½	1.41 m.
Track, front ...	4 0½	1.24 m.	4 0½	1.24 m.
Track, rear ...	4 1½	1.25 m.	4 1½	1.25 m.
Turning circle (approx.) ...	36 0	11.00 m.	36 0	11.00 m.
Body capacity ...	110 cu. ft.	3.12 cu. m.	40 cu. ft.	1.13 cu. m.
Weight, including tools, spare wheel, oil, water and heater; less fuel (and passenger seat in van) ...	19½ cwt.	1003.3 kg.	19½ cwt.	1003.3 kg.



THE AUSTIN MOTOR COMPANY LIMITED  
LONGBRIDGE · · · BIRMINGHAM

AUSTIN MOTOR EXPORT CORPORATION LIMITED  
LONGBRIDGE · · · BIRMINGHAM · · · ENGLAND

Printed in England

Publication No. 2148/A