

1978 Dodge ASPEN



Aspen Custom four-door sedan.



The Aspen four-door sedan.

### Times are changing. But Aspen doesn't have to.

That's because Aspen has been styled, sized, and powered right...right from the start. So the changes you see in Aspen for 1978 are noteworthy additions to Aspen's traditional modern looks, greater comfort, and welcome efficiency. Aspen's new good looks, for example, aren't hard to find. There are a new grille, new decorative trim, and new accents. New rear styling to give this latest Aspen ready identification. In total—a look of richness far beyond Aspen's price.

A choice of exterior and interior option packages is also available in Aspen Custom and Special Edition designations. You'll want to talk to your Dealer about the combinations that best suit your taste.

When it comes to greater comfort, be our guest. Try an Aspen. You'll learn that Aspen's interior is actually larger than that of some luxury cars costing far more. And, for 1978, Aspen's roominess is enhanced by an extra-spacious trunk...so that things don't get in the way of people. Nor is Aspen's incredible ride an illusion. It's based on advanced transverse torsion bars at front and multileaf springs at rear.

Another Aspen talent: efficiency. A 225 Slant Six coupled to a three-speed manual transmission is provided as standard equipment. But here's the big efficiency news: An exclusive new lockup clutch has been added to the torque converters of most optional TorqueFlite transmissions. Result: measurable improvement in Aspen's fuel economy in both city and highway operation.

1. Standard with the Custom Interior Package is this cloth-and-vinyl bench seat.
2. The Aspen trunk capacity offers generous space for family gear.
3. With Aspen Special Edition coupe and sedan interior package, this is the optional 60/40 split-bench seat in velour cloth. Fold-down center armrest and passenger-side recliner included.

Some items pictured on vehicles on this and other pages of this catalog are extra-cost options.



Aspen Special Edition four-door sedan.



Aspen Special Edition wagon.



Aspen Custom wagon.



The Aspen wagon.  
**You'll find it an amazing lot of car for its size.**

You'll like the new Aspen wagon's capacity to please...as well as to haul cargo. In fact, because the wagon achieves such a splendid balance between luxury and utility, some people think of it as a five-door sedan.

The wagon, like all Aspens, is gifted with "just right" dimensions. The compact wheelbase is 112.7 inches. The overall length of 201.2 inches offers plenty of passenger space which converts into well over 70 cubic feet of cargo area when you need it. Yet all this comes in a car that makes parking and maneuvering in traffic a cinch.

The Aspen wagon also comes furnished with "just right" power. The well-tested 225 Super Six is standard,\* an engine that supplies plenty of urge even when you travel in the "full load" mode. Power disc brakes provide effective braking power, too, and a generous 19.5 gallon fuel tank assures

a "just right" travel range between fill-ups. Heavy-duty suspension and stout F78x14 glass-belted tires are ready to handle the wagon's occasional heavy loads.

And if you want your wagon to look extra special, you'll approve Aspen's Special Edition exterior and interior luxury appearance options—including things like wood-grained body sides, full carpeting the length of the cargo area, and lockable storage compartments for such items as cameras, binoculars, and other valuables.

There's one best way to get to know the Aspen wagon: Test drive it at your Dodge Dealer's soon. You'll quickly discover why the wagon has offered such wide appeal to ever-increasing numbers of American wagon owners.

\*225-1 Six standard in California and high altitude areas.



1. The all-vinyl bench seat for the wagon is standard.
2. The cargo area of the Aspen wagon with Special Edition Interior Package is fully carpeted. Liftgate ajar warning system is standard.
3. The Special Edition optional Interior Package is this smart 60/40 cloth-and-vinyl split-bench seat with center fold-down armrest and passenger-side recliner.



Aspen Special Edition coupe with T-bar roof option.



Aspen sport coupe with two-tone paint option.



The Aspen two-door sport coupe.

**It makes a great deal of uncommon sense.**

Anybody with a nose for value is going to find a lot to like in the Aspen sport coupe, or in its more luxurious versions—the Aspen Custom and Special Edition.

Here are cars that offer significant economies in a number of ways.

One of these: reduced weight. Poundage has been pared from Aspen for '78... in such areas as the windshield, inner body panels, moldings, headlining materials, brakes, and more. It's the kind of engineering that accents efficiency in all aspects of basic automotive design.

You'll admire other Aspen coupe values, too. Like the bright new styling changes that include ten new colors for '78. Like the most innovative suspension system in its class, featuring transverse torsion bars at front and multileaf springs at rear. And the liberal choice of Custom and Special

Edition Exterior and Interior Packages you'll find available to add further distinction to your coupe.

You'll also find the compact dimensions of the coupe a real benefit in tight parking situations and in traffic. With a wheelbase of 108.7" this nimble Aspen offers agile handling in the city as well as generous interior space for the long-distance traveler.

In fact, we urge you to consult your Dodge Dealer as you make your choice of the coupe's optional features. The list is long and impressive—with such desirable features as air conditioning, automatic speed control, a variety of radios, a new integral CB transceiver, and many other items.

Get a lot closer to this uncommonly worthwhile car. You'll see immediately how much it contributes to Aspen's remarkable success story.



1. This newly styled all-vinyl bucket seat design with available center console is optional on Aspen coupes.
2. The Aspen instrument panel features modular construction with controls placed for easy, convenient use.
3. Super-soft all-vinyl 60/40 split-bench seat is optional with Aspen's SE Interior Package (coupes and sedans). Includes center armrest and passenger-side recliner.



Super Coupe... a super Aspen.



Super sleek... the R/T Sport Pak.



Super smooth... the R/T Coupe.

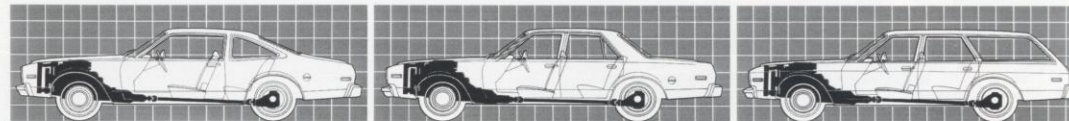

Aspen two-door sport coupe.

Aspen four-door sedan.

Aspen wagon.

Aspen specifications:

### Some basic facts to help you make your choice.

Dimensions: (inches)	Two-Door	Four-Door	Wagon
Wheelbase	108.7	112.7	112.7
Length	197.2	201.2	201.2
Width, overall	73.3	73.3	73.3
Height	53.3	55.3	55.7
Tread, front	60.0	60.0	60.0
Tread, rear	58.5	58.5	58.5
Headroom, front	37.4	39.2	39.2
Legroom, front	42.5	42.5	42.5
Headroom, rear	35.9	37.5	38.7
Legroom, rear	31.7	36.6	36.6

#### Important Wagon Dimensions: (inches)

Maximum height of rear opening	27.3
Maximum cargo height	30.9
Back of front seat to end of cargo floor	81.4
Width between wheelhouses	43.3
Cargo capacity (cubic feet)	73.1

#### Engines:

225 Six, 225 Super Six, 318 V8, 360 V8. (Electronic Lean Burn System on 318 and 360 V8 engines; not included with 360 four-barrel engine in high altitude areas or California.)

#### Transmissions:

Three-speed, floor-mounted manual (standard).<sup>1</sup> Four-speed, floor-mounted manual with overdrive (optional).<sup>1</sup> TorqueFlite automatic (optional).

#### Suspensions:

Front: Transverse torsion bars and sway bar (fully isolated). Rear: Asymmetrical multileaf springs.

#### Brakes:

Front: Manual disc (sedans and coupes). Power disc (wagons). Rear: Drum (sedans and coupes). Power drum (wagons).

#### Electrical System:

Battery: 325-amp, 440-amp with 360 V8. Alternator: 41-amp. Other features: Electronic Ignition System, solid-state voltage regulator.

<sup>1</sup>Not available in high altitude areas or California.

**NOTE:** A number of optional tire/engine/model combinations are available. Be sure to consult your Dealer for details.

#### Tires:

D78x14-inch polyester black sidewall (standard sedans and coupes).  
F78x14-inch glass-belted black sidewall (standard wagons).  
FR78x14-inch fiber-glass-belted radial-ply blackwall (standard R/T coupes only).  
GR60x15-inch Aramid fiber-belted radial with raised white letters (standard Super Coupe only).

#### Capacities:

Fuel (nonloaded regular): 19.5 gallons (V8s and wagons). 18 gallons (Sixes).  
Trunks: 14.8 cubic feet (sedans and coupes). 16.1 (coupes) or 16.4 (sedans) with optional Space Saving spare tire.  
Cargo: 73.1 cubic feet (wagons).

#### STANDARD EQUIPMENT

Ashtray, front • Coat hooks • Directional signals • Color-keyed passenger compartment carpeting • 225-1 six-cylinder engine (coupes, sedans), 225-2 Super Six (wagons) • Trunk mat (coupes, sedans) • Hazard warning flashers • Heater/detroster • Single horn • Instrument panel safety padding • Lane-change features (in turn signal switch) • Headlight switch and wiper switch lights • Brake system warning lights • Backup lights • Dome light • Parking brake warning light • Selector lever quadrant with automatic transmission • Side marker lights (reflectors) • Interior light switch (front door) • Inside rearview mirror • Manual left outside chrome mirror • Liftgate and fold-down second seat (wagons only) • Two-way manual front seat adjustment • Unibelt passenger restraint system • Two-spoke padded steering wheel with soft horn button • Hubcaps • Two-speed windshield wipers • Heavy-duty suspension (wagons) • Liftgate ajar warning system (wagons) • Bright roof drip-rail moldings • Bright quarter-window moldings (coupes and wagons).

#### MAJOR EQUIPMENT SUMMARY

	Two-Door Coupe	Four-Door Sedan	Wagon
225 1-barrel six-cylinder engine	S	S	S (2)
225 2-barrel Super Six engine	E/C	E/C	S (2)
Three-speed, floor-mounted manual transmission	S (1)	S (1)	S (1)
Four-speed, floor-mounted manual transmission	E/C (1)	E/C (1)	E/C (1)
TorqueFlite automatic transmission	E/C (3)	E/C (3)	E/C (3)
Bright windshield and head lamp surround moldings	S	S	S
Bright quarter-window moldings	S	N/A	S
Bright roof drip-rail moldings	S	S	S
Hubcaps	S	S	S
Wheel-lip moldings	E/C (4)	E/C (4)	E/C
D78x14 polyester black sidewall tires	S	S	N/A
F78x14 glass-belted black sidewall tires	N/A	N/A	S
Full vinyl roof	N/A	E/C	N/A
Halo vinyl roof	E/C	N/A	N/A
Landau vinyl roof	E/C	N/A	N/A

Code: S—Standard; E/C—Extra cost; N/A—Not available.

- Not available in California or high altitude areas.
- Super Six standard on wagons except in high altitude areas and in California—225 1-barrel standard on wagons in high altitude areas and in California.
- Required extra-cost option in California and high altitude areas.
- Included with two-tone exterior paint and tape stripes (A53) on coupes. Also included with SE Exterior Package on coupes and sedans.

The Aspen Special coupes.

### The Aspen sports team is always ready to play.

Enthusiasts, rejoice! Aspen comes on strong with three spectacular sports editions: the Super Coupe, the R/T, and its tougher-looking brother, the R/T Sport Pak.

Now, about that Super Coupe... the one that looks as if it's ready for the main go at LeMans. It's coming soon... with a rich dark brown body color with contrasting black-finish hood, front fender tops, head lamps, wiper arms, front and rear bumpers and remote-control racing mirrors.

Body side and roof tape striping provide a vivid contrast. Then, there are the wheel flares, front and rear spoilers, quarter window louvers, 15x8-inch special GT wheels with GR60x15 raised white letter Aramid fiber-belted radials. All this show is backed by a 360 four-barrel V8 plus a heavy-duty suspension and rear antisway bar. Why not drive one? Just so you can be sure it does what it promises.

Only a step away from the Super Coupe comes the R/T Sport Pak. This one takes the R/T Package, adds a front air spoiler, wheel flares, quarter window louvers, and rear deck spoiler and adds a superb finishing touch with tricolor stripes on a White or Black exterior. Five interior selections include the spectacular Spectrum seat design—just like the one in our Aspen Options section. Sport Pak. Couldn't have been better named!

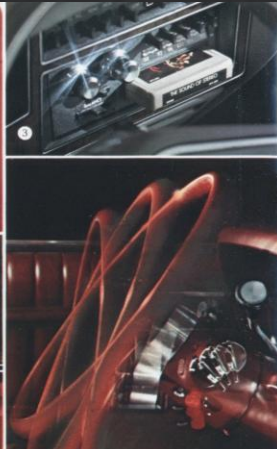

Aspen optional equipment.

## Your choices have never before been as wide or as satisfying.

1. Spectrum cloth-and-vinyl bucket seats with complementary door trim panels are totally unique. (Available on coupes only.)
2. Air conditioning and AM/FM push-button radio control panels permit easy use.
3. AM/FM stereo radio with eight-track tape player gives you a wide choice of entertainment.
4. AM/FM stereo radio with 40-channel CB transceiver is a welcome "companion."
5. Tilt steering wheel and column adjusts to seven positions.
6. Power door locks are considered a worthwhile safety-security aid by many.
7. Automatic speed control holds speed to the one you've selected. (TorqueFlite required.)

8. Heavy-Duty Trailer-Assist Package is just the thing for the trailering fan.
9. Smart T-bar roof for coupes is a wonderful boon to the open air enthusiast.

**Optional Equipment - All Models:** Air conditioning (power brakes required—power steering required on six-cylinder models in California) • Sure Grip differential axle • Rear armrest with ashtray • 500-amp Long Life battery • Bumper guards, front and rear • Protective rub strips (bumper guards required) • Electric rear window defroster • Blower-type rear window defogger • Door-edge protectors • Electronic clock with digital display • Color-keyed floor mats, front and

rear • Console (only with bucket seats and TorqueFlite) • Glove box lock • Locking gas cap • Tinted glass, all windows or windshield only • Inside hood release • Dual horns • Day/night inside mirror • Mirrors, remote-control left and right • Power front disc brakes (required with V8 and air conditioning) • Power left bucket or left 60/40 split-bench seat • Radios, AM, AM/FM, AM/FM stereo, AM, AM/FM stereo with eight-track tape, AM, AM/FM with CB transceiver and power tri-band antenna • Deluxe windshield wipers with intermittent wipe • T-bar roof (coupes only) • Air deflector (wagons only) • Cargo compartment carpeting

and storage bins (wagons only) • Luggage rack (wagons only) • Power luggage release (TorqueFlite required—wagons only) • Automatic speed control (TorqueFlite required) • Heavy-duty suspension (standard wagons) • Space Saving spare tire (not available on wagons; standard with radial tires) • Tilt steering wheel (with automatic transmission and power steering only); Luxury steering wheel (power steering required); Tuff steering wheel (power steering required) • Chrome-styled road wheels • Rallye road wheels • Wire wheel, deluxe, and premium covers (14-inch).

## Aspen Interior and Exterior Packages consider just about every taste.

### Custom Exterior Package

Not available with R/T Package for coupes, Special Edition Exterior Package for coupes and sedans, or Special Edition Wagon Wood-Grained Group. Includes: Color-keyed full-length body side molding with vinyl insert • Belt moldings • Rear deck lower applique (sedans and coupes only) • Door upper frame moldings (wagons only).

### Custom Interior Package

Sedans and coupes only. Not available with Special Edition Interior Package. Includes: Custom seat and interior trim • Vinyl bucket seats available at extra cost • Hood silencer pad • Rear armrest with ashtray • Wood-grained instrument panel cluster • Cigarette lighter • Day/night inside mirror • Molded cloth headliner • Custom exterior nameplates (not included when R/T Package is ordered on coupes).

### Special Edition Exterior Package

Sedans and coupes only. Not available with R/T Package on coupes. Includes: Custom Exterior Package • Hood ornament and center molding • Hood tape stripe • Body side accent tape stripes (coupes only, and requires landau vinyl roof option) • Door upper frame moldings (sedans only) • Wheel-lip moldings.

### Special Edition Interior Package

Sedans and coupes only. Not available with Custom Interior Package or R/T Package. Includes: Premium all-vinyl bucket or optional all-vinyl or cloth-and-vinyl 60/40 seat with passenger-side recliner • Rear armrest and ashtray • Shag carpeting (with automatic transmission only) • Left-hand outside remote-control mirror • Wood-grained instrument panel cluster and glove box door • Luxury steering wheel (included only when power steering is ordered) • Cigarette lighter • Day/night inside mirror • Pedal dress-up • Molded cloth headliner • Special Edition exterior nameplates • Deluxe Insulation Package • DR78x14 glass-belted black sidewall radial-ply tires.

### Special Edition Wagon Wood-Grained Group

Not available with Custom Exterior Package. Includes: Wood-grained body side and rear exterior panel trim • Hood ornament and center moldings • Door upper frame moldings • Belt moldings.

### Special Edition Wagon Interior Package

Includes: Custom vinyl bench seat, optional vinyl bucket seats, or optional cloth-and-vinyl 60/40 seat with passenger-side recliner • Rear

armrest with ashtray • Wood-grained instrument panel cluster • Cigarette lighter • Day/night inside mirror • Cargo compartment carpeting and covered lockable storage bins • Special Edition exterior nameplates • Hood silencer pad.

### Light Package

Includes: Trunk or cargo light • Glove box light • Fender-mounted turn signals • Ashtray light • Ignition light with time delay • Headlight-on buzzer • Map/courtesy light.

### Deluxe Insulation Package

Includes: Noise Reduction Package • Special sound insulation and hood silencer pad.

### Protection Group

Includes: Glove box lock • Inside hood release • Door-edge protectors.

### Two-Tone Decor Package

Coupes only. Not available with Custom and Special Edition Exterior Packages or R/T Package. Includes: Two-tone paint • Sill molding • Belt molding • Rear deck lower applique • Hood ornament and center moldings.

### R/T Package

Coupes only. Not available with two-tone paint, Custom or SE Exterior Packages, SE Interior Package, wheel-lip moldings or with wheel

covers. (Eight-cylinder engine only.) Includes: FR78x14 fiber-glass-belted black sidewall tires • Heavy-duty suspension • Rallye wheels less trim rings • Red-painted grille treatment • R/T multicolored body side, hood, and rear tape stripes • R/T decals and grille medallion • Sill molding with black-finish paint below • Dual remote-control racing mirrors—body-colored and striped—available in eight most popular exterior colors only (chrome with other exterior colors).

### R/T Decor Group

R/T Package required. Not available with R/T Sport Pak. Coupes only. Includes: Belt moldings • Rallye wheel trim rings.

### Heavy-Duty Trailer-Assist Package

Sedans or wagons only. Includes: Heavy-duty 65-amp alternator • 3.2 performance side ratio • Long Life 500-amp battery • Heavy-duty suspension (standard wagons) • Auxiliary transmission oil cooler • Seven-wire harness with jumper • Extra-wide rim road wheels • Heavy-duty cooling system • Variable load turn signal flasher • Power steering oil cooler.

NOTE: Must order TorqueFlite automatic transmission and largest available steel-belted radial-ply tires. Also requires heavy-duty engine option: (1) 360-2V or (2) 360-4V in California or high altitude areas.

Engineering:

## One more reason why Aspen is the most successful car in Dodge history.

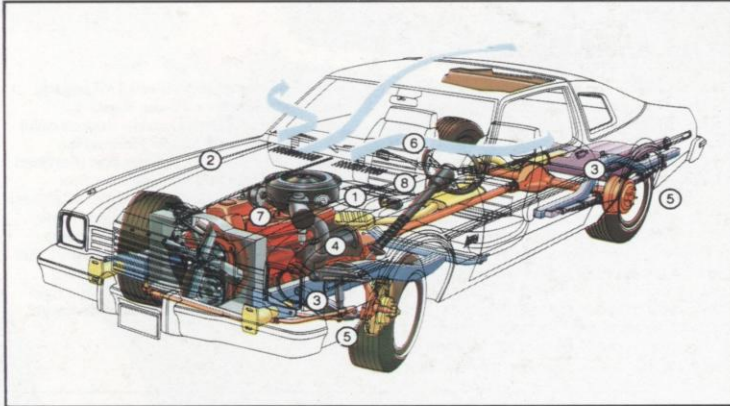

### 1. New TorqueFlite automatic transmission.

There's a remarkable new lockup clutch feature for 1978 on most TorqueFlite installations.\* It offers better fuel economy in both city and highway driving. The lockup design is another Aspen plus sure to be appreciated by efficiency-minded owners.

### 2. Unibody construction.

Body structural members and panels are welded into a single unit with more than 3000 separate welds.

### 3. Suspension system.

Employs transverse torsion bars at front and multileaf springs at rear to give a comfortable, well-balanced ride. Torsion-bar design has long been a Chrysler engineering strong point.

### 4. Engine.

Well-tested 225 Six and Super Six provide flexible power in the city or on the highway.

\*See your Dodge Dealer for full details.

Standard on Aspen coupes and sedans and Aspen wagon, respectively.

### 5. Brakes.

Disc at front, drum at rear for well-balanced braking—power braking is offered and standard on wagons.

### 6. Windshield wipers.

New intermittent system is available. Can be programmed to a choice of time-delay sequences. Ideal for foggy or misty weather conditions.

### 7. Electronic Lean Burn System.

It's standard on 318 V8, both two- and four-barrel versions. Also standard on 360 V8 two- and four-barrel engines, except in California and high altitude areas. Helps promote efficient fuel use.

### 8. Electronic Ignition.

Because it does away with points and condenser, it reduces number of service functions. It's an integral part of Electronic Lean Burn System. Helps extend spark plug life up to 30,000 miles with unleaded fuel.



Aspen two-door sport coupe with Special Edition Packages.



Aspen two-door sport coupe with Custom Packages.



Aspen four-door sedan with Special Edition Packages.



Aspen four-door sedan with Custom Packages.



Aspen wagon with Special Edition Packages.



Aspen wagon.



Aspen two-door sport coupe.



Aspen four-door sedan.

### Ten new Aspen colors are featured for 1978.



\*New for 1978. (1) Not available on wagons. (2) Coupes only.

### Vinyl roof cover in seven different colors

is available at extra cost as full-style on four-door sedans only, as halo-style and landau-style with plugged quarter windows on sport coupes only in Red,† Silver,† Green,† White, Black, Tan,†† or Blue.

†New for 1978. ††N/A halo-style.

### Two-tone exterior paint—Color combinations

for coupes only, with Dark Silver Metallic/Pewter Gray Metallic, Crimson Red Sunfire Metallic/Tapestry Red Sunfire Metallic, Cadet Blue Metallic/Starlight Blue Sunfire Metallic, Mint Green Metallic/Augusta Green Sunfire Metallic, and Light Mocha Tan/Caramel Tan Metallic.



Litho in U.S.A. 8-77

### Automotive Sales Division Chrysler Corporation

All product illustrations and specifications are based on authorized information. Although all descriptions are believed correct at publication approval, accuracy cannot be guaranteed. Some of the equipment shown on product illustrations is optional at extra cost. Automotive Sales Division reserves the right to make changes from time to time, without notice or obligation, in prices, specifications, colors, and materials, and to change or discontinue models.

Form No. 81 205 8008 (2MM)