

DODGE 71



CHARGER / CORONET

CHARGER



THE LIMITED EDITION CARS ENVY ITS LOOKS... BUT THEY CAN'T TOUCH ITS PRICE. Here it is, America, the 1977 version of the "Great Shape"... styled to stand out from the limited edition cars costing one or two thousand dollars more, but priced right down with standard intermediate hardtops. And now Charger offers a full range of two-doors—for him... for her... for the family—for a lot less than you'd expect. Of course, you still get a lot. Like 24 standard safety features. And new standard features like concealed wipers. Custom-contoured door handles, and ventless side windows for more security. (We're always trying to improve the "shape" you're in.) So go ahead. Pick the Charger that's priced for you. Who cares if your friends think you paid a lot more.

CHARGER

The great shape at standard hardtop prices.
That's hard to top.



The Great Shape hasn't let success go to its price. It's still a beautiful bargain. This is our lowest priced Charger hardtop... the standard Charger two-door. It's some standard. And it has some Standard Equipment List. One that includes a color-keyed steering wheel with simulated wood-grained insert and a Keyless Door Locking System. Of course, you can make your Charger just the way you want it by checking Charger's exciting Optional Equipment List. However you want your Charger, you'll be in great shape. So why settle for less when you can have Charger's brand of excitement at intermediate hardtop prices? Charger. There's just no topping it.

COUPE

Here's a Coupe you can cope with.



Welcome, sports lovers, to our lowest priced Charger. Surprised? Thought you would be, but there's even more. Charger Coupe has all-vinyl-covered seats with a big comfortable bench up front. See, your pocketbook isn't the only thing that won't suffer. Sounds like a family sports car, you say... now you're catching on. Continuing its economy drive, Charger Coupe offers a gas-dieting 225 Six or the slightly more indulgent 318 V8. Either way, at Charger Coupe's price, your budget won't be coupéd up.

STANDARD EQUIPMENT, CHARGER AND COUPE: 318-cu.-in. V8 or 225-cu.-in. 6-cylinder engine • 3-speed manual transmission, shift lever on steering column • All-vinyl, front, full-width bench seat • Heater/del-froster • 2-speed concealed wipers • Keyless Door Locking System • Foot-operated parking brake • 3-spoke color-keyed steering wheel • Glove box lock • Dome light • Tor-sion-bar front suspension • Rubber floor mats. CHARGER includes the above with these additions and changes: Color-keyed carpeting • Cigarette lighter • Simulated wood-grained door trim inserts • Simulated wood-grained instrument panel applique • Color-keyed steering wheel with simulated wood-grained insert • Inside day/night mirror.

Charger 500, left.

500

The sporty hardtop that's a real softy inside. It's soft on your budget, too.

If you're the kind who wants your Charger sporty inside as well as outside . . . Charger 500 fills the bill beautifully. Start with vinyl bucket seats, with integral head restraints, comfortably contoured for easy driving. For an extra touch of plushness, simulated wood-grained instrument panel and door trim.

And to continue the theme of your color scheme, color-keyed carpeting and color-keyed steering wheel—with simulated wood-grained insert. Of course, there's more. But we don't want to spoil all your fun. Check out Charger 500 with your Dodge Dealer. He'll give you the whole story.

STANDARD EQUIPMENT, CHARGER 500: 318-cu.-in. V8 • 3-speed manual transmission, shift lever on steering column • All-vinyl bucket seats with integral head restraints • Heater/defroster • 2-speed concealed wipers • Keyless Door Locking System • Foot-operated parking brake • 3-spoke color-keyed steering wheel with simulated wood-grained insert • Glove box lock • Dome light • Torsion-bar front suspension • Color-keyed carpeting • Cigarette lighter • Simulated wood-grained door trim inserts • Simulated wood-grained instrument panel applique, with hooded, circular instrumentation including: 150-mph speedometer, oil pressure and fuel gauges, temperature and alternator gauges • Glove box light • Map/courtesy light • Ashtray light • Side paint stripes • Deluxe wheel covers.



SE

We call it the Special Edition because of the special additions.

This is the Charger that was designed for people who demand personal touches . . . not just touch-ups. Charger SE offers all the extras, all over, and many of them are standard. For openers, there are concealed headlights and a hood release located right on the dash. Inside, a distinctive cloth-and-vinyl split-back bench seat with center armrest. To show you just how plush Charger SE is . . . it even has a carpeted trunk. Really! Plus wheel covers and special sound-silencing insulation. And to top it all off, Charger SE has a very stylish landau vinyl roof in a choice of four tasteful colors. Now that you're getting the idea of what Charger SE is all about, why not discover the rest yourself. You'll find Charger Special Edition is a welcome addition.

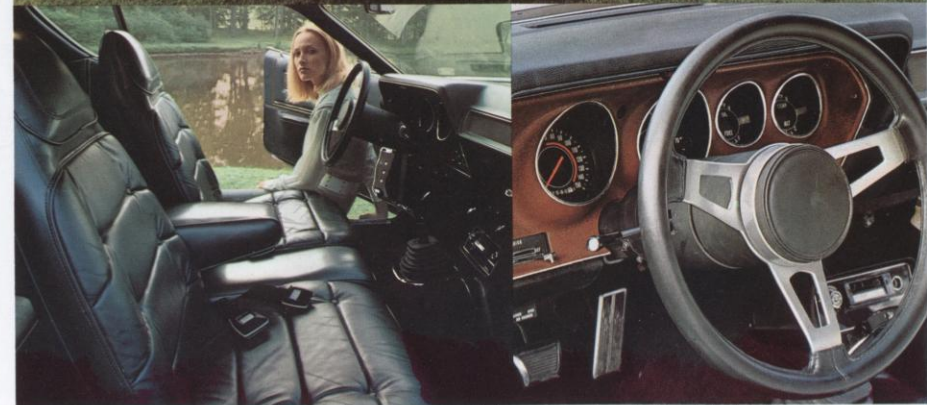

STANDARD EQUIPMENT, CHARGER SE: 318-cu.-in. V8 • 3-speed manual transmission, shift lever on steering column • Split-back cloth-and-vinyl bench seat with center armrest • Heater/defroster • 2-speed concealed wipers • Keyless Door Locking System • Foot-operated parking brake • 3-spoke color-keyed steering wheel with simulated wood-grained insert • Glove box lock • Dome light • Torsion-bar front suspension • Color-keyed carpeting, except trunk and spare tire cover carpeting • Cigarette lighter • Simulated wood-grained door trim inserts • Simulated wood-grained instrument panel applique, with hooded, circular instrumentation including: 150-mph speedometer, clock, oil pressure and fuel gauges, temperature and alternator gauges • Glove box light • Map/courtesy light • Ashtray light • Landau vinyl roof • Concealed headlights • Deluxe wheel covers • Ignition switch light with time delay • Instrument panel hood release.

R/T

When this one snarls... they listen.

It's a bold sound. A brawny sound. A defiant sound. The sound of 440 cubic inches of metal muscle ready to move the moment you are. That's the sound of Charger R/T. Sound interesting? Read on. Charger R/T also has some silent partners. A main supporter is the extra-heavy-duty handling package. This includes high-rate torsion bars, heavy-duty shock absorbers, extra-heavy-duty rear springs with special right rear spring and sway bar, plus heavy-duty

brakes. If you really want to push your performance image, you can order your Charger R/T with front and rear aerodynamic spoilers, special color-keyed racing mirrors, and color-keyed bumpers. Of course, if all this is a little too obvious for you, you can have your Charger R/T in a simpler version... without the performance stripes, if you wish. But Charger R/T's sound will still come in loud and clear.

STANDARD EQUIPMENT, CHARGER R/T: 440 Magnum V8 • TorqueFlite automatic transmission, shift lever on steering column • All-vinyl bucket seats with integral head restraints • Heater/defroster • 2-speed concealed wipers • Keyless Door Locking System • Foot-operated parking brake • 3-spoke color-keyed steering wheel with simulated wood-grained insert • Glove box lock • Dome light • Color-keyed carpeting • Cigarette lighter • Simulated wood-grained door trim inserts • Simulated wood-grained instrument panel applique, with hooded, circular instrumentation including: 150-mph speedometer, oil pressure and fuel gauges, temperature and alternator gauges • Glove box light • Map/courtesy light • Performance hood with blackout treatment • Longitudinal performance stripes • Extra-heavy-duty suspension (includes high-rate torsion bars, heavy-duty rear spring and sway bar, and heavy-duty shock absorbers) • Heavy-duty brakes: 11" x 3", front; 11" x 2 1/2", rear • G70 x 14 wide-tread, raised white letter, bias-belted tires • Dual exhausts.



SUPER BEE

The car you can swing with
at a price you can swing.

And in this corner... Super Bee. With the credentials of a great contender. The main punch is supplied by the 383 Magnum V8 that uses regular fuel. To set this power in motion, a three-speed fully synchronized transmission with floor-mounted shift. For heavy road work, Super Bee has a Rallye Suspension Package that includes heavy-duty torsion bars, heavy-duty rear spring and sway bar, plus heavy-duty shock absorbers and brakes. And this is only round one. There's more. Like Super Bee's wide solid stance or optional 440 SixPack or Hemi engines. One look tells you it's in great shape—with performance hood and special stripes. All this at a price that won't put you on the ropes. Check out Super Bee. You'll know it has what it takes to be a winner.



STANDARD EQUIPMENT, CHARGER SUPER BEE: 383 Magnum V8 (regular fuel) • 3-speed fully synchronized transmission with floor-mounted shift • All-vinyl, front, full-width bench seat • Heater/defroster • 2-speed concealed wipers • Keyless Door Locking System • Foot-operated parking brake • 3-spoke color-keyed steering wheel with simulated wood-grained insert • Glove box lock • Dome light • Color-keyed carpeting • Cigarette lighter • Simulated wood-grained door trim inserts • Simulated wood-grained instrument panel applique, with hooded, circular instrumentation including: 150-mph speedometer, oil pressure and fuel gauges, temperature and alternator gauges • Performance hood with blackout treatment • Longitudinal performance tape stripes • Rallye Suspension Package (includes heavy-duty torsion bars, and heavy-duty rear springs, sway bar, and heavy-duty shock absorbers) • Heavy-duty brakes: 11" x 3", front; 11" x 2 1/2", rear • F70 x 14 wide-tread, white sidewall, bias-belted tires • Dual exhausts.

For more information about performance options and accessories, ask your Dealer for the Dodge Performance Catalog.

CORONET

THE FOUR-DOOR SEDAN THAT DIDN'T START OUT AS SOMETHING ELSE. THE LOW PRICE WILL START YOU THINKING. Did you ever notice how most four-doors look stodgy, overweight, out of proportion? That's because they started out as two-doors. Dodge Coronet didn't. It was designed and built as a four-door from the ground up. By taking this approach, Dodge was able to concentrate on the things four-door-sedan buyers really want in their cars. Like undisturbed exterior styling lines. The wide solid stance of a true road car. An interior designed for maximum room and comfort. Is there really any other way to build a four-door sedan? Coronet's price says "no." Think about it.



CORONET

For openers,
you get four wide doors.



If you're a family man, you know why four doors are better than two. For one thing, they are a way to get the kids off your back . . . when they're trying to get in and out. They also make it easier for mother to load and unload her shopping bags. Of course, doors are only part of the appeal. There's Coronet's distinguished look of big-car luxury set on a 118" wheelbase. Coronet also offers new standard features such as concealed wipers with an articulated blade on the driver's side for wider vision. For appearance and security, there are ventless front side windows and Custom-contoured door handles. Inside, there's a generous helping of comfort with all-vinyl seats. (Very easy to clean.) And all Coronet models have 24 standard safety items for your protection. But above all, Coronet is a family car that fits the whole family and the family budget.



STANDARD EQUIPMENT, CORONET: 318-cu.-in. V8 or 225-cu.-in. 6-cylinder engine • 3-speed manual transmission, shift lever on steering column • All-vinyl, front, full-width bench seat • Heater/delraster • 2-speed concealed wipers • Keyless Door Locking System • 3-spoke color-keyed steering wheel • Foot-operated parking brake • Glove box lock • Dome light • Torsion-bar front suspension • Color-keyed rubber floor mat • Cigarette lighter • Inside day/night mirror.

Coronet Brougham, left.

CUSTOM

The four-door sedan
with a plan.

The plan was to make Coronet Custom a little plusher, a little nicer, a little richer—for the person that knows little things mean a lot. The plan began with simulated wood-grained door trim inserts and instrument panel applique. (These items are usually reserved for more expensive cars.) Then we laid in the lush color-keyed carpeting. And to accent your color theme, we color-

keyed the three-spoke steering wheel. (Which, by the way, has a simulated wood-grained insert and a horn button on each spoke.) To cover the soft foam seats, we chose elegant cloth and vinyl. Sound as if you might be indulging yourself too much? Don't believe it. Coronet Custom's low price was part of the plan, too.

STANDARD EQUIPMENT, CORONET CUSTOM: 318-cu.-in. V8 or 225-cu.-in. 6-cylinder engine • 3-speed manual transmission, shift lever on steering column • Pleated cloth-and-vinyl, front, full-width bench seat • Heater/defroster • 2-speed concealed wipers • Keyless Door Locking System • Foot-operated parking brake • 3-spoke color-keyed steering wheel with simulated wood-grained insert • Glove box lock • Dome light • Torsion-bar front suspension • Color-keyed carpeting • Cigarette lighter • Simulated wood-grained door trim inserts • Simulated wood-grained instrument panel applique.



BROUGHAM

We named it
Brougham
to fool your wife.



O.K., sport, so you gotta buy a four-door sedan to fit the family and satisfy the spouse. Relax. That's what Coronet Brougham is all about. Here's the car that gives you all the room, comfort, and style you want . . . plus a few extras for you that your wife just wouldn't understand. For instance, there's a standard 318 V8. Not massive, but quite respectable. There's a fully synchronized three-speed manual shift. On the dash, you'll find a 150-mph speedometer and oil pressure gauge mounted in the simulated wood-grained instrument panel. Outside, there are dual body side paint stripes. So if you want to put a little excitement in your four-door-sedan driving, Coronet Brougham was made for you . . . but named for your wife.



STANDARD EQUIPMENT, CORONET BROUGHAM: 318-cu.-in. V8 • 3-speed manual transmission, shift lever on steering column • Cloth-and-vinyl, split-back bench with center armrest and integral head restraints • Heater/defroster • 2-speed concealed wipers • Keyless Door Locking System • Foot-operated parking brake • 3-spoke color-keyed steering wheel with simulated wood-grained insert • Glove box lock • Dome light with automatic rear door switch • Torsion-bar front suspension • Color-keyed carpeting • Cigarette lighter • Simulated wood-grained door trim inserts • Simulated wood-grained instrument panel applique, with hooded, circular instrumentation including 150-mph speedometer, oil pressure and fuel gauges, temperature and alternator gauges • Glove box light • Ashtray light • Map/courtesy light • Deluxe wheel covers • Dual body side paint stripes.

CORONET and CUSTOM

Either way,
you get a wagon full of extras.

Here are some wagons you'll welcome. The 1971 Coronet station wagons. There's one priced right for every family, depending on their degree of indulgence. This year, all Coronet wagons have the Dual Action tailgate, and all three-seat wagons have as standard equipment the Auto-Lock electric tailgate which prevents the door from accidentally opening when the ignition is on. Popular optional features include a "rear window cleaning vane" and "lockable rear luggage compartment." Of course, there's lots more. Check over the Standard and Optional Equipment Lists and you'll come up with the wagon that's styled, priced, and equipped just the way you want it. What wagon could be more welcome?



Coronet wagon.



Coronet Custom wagon.

STANDARD EQUIPMENT, WAGONS: 3-speed manual transmission, shift lever on steering column • Heater/defroster • 2-speed concealed wipers • Keyless Door Locking System • Foot-operated parking brake • 3-spoke color-keyed steering wheel • Glove box lock • Dome light • Torison-bar front suspension • Cigarette lighter • Dual Action tailgate with concealed hinges • Manual lock on tailgate • Rear compartment cargo light (standard, 3-seat wagons; optional, 2-seat wagons) • Rear door automatic dome light switch (standard, Crestwood; optional, Coronet and Custom) • Simulated wood-grained instrument panel applique, with hooded, circular instrumentation including: 150-mph speedometer, oil pressure and fuel gauges, temperature and alternator gauges (Crestwood) • Exterior simulated wood-grained overlay (Crestwood) • Color-keyed carpet for rear floor well (3-seat wagons) • Auto-Lock electric tailgate lock system (standard, 3-seat wagons; optional, 2-seat wagons) • Deluxe wheel covers (standard on Crestwood) • 255-cu.-in. Six (Coronet and Custom 2-seat wagons only) • 318 V8 (standard V8 for all Coronet wagons) • Color-keyed rubber floor mat (Coronet) • Color-keyed carpeting (Custom and Crestwood) • Vinyl front bench—Blue, Tan, or Black interior trim colors (Coronet and Custom) • Vinyl split-back front bench with center armrest—Blue, Green, Tan, or Black interior trim colors (Crestwood only) • Color-keyed steering wheel with simulated wood-grained insert (standard, Custom and Crestwood; optional, Coronet).

CRESTWOOD

The beautiful family wagon
that fits
the family budget
beautifully.

Crestwood bucket back bench seat with folding center armrest—all-vinyl, standard.



Dodge's Dual Action tailgate opens like this for passengers (and you don't have to lower the window) ...



... or like this for loading cargo. (You can lay a 4 x 8 ft. piece of plywood flat on the floor.)



CHARGER/CORONET SPECIFICATIONS

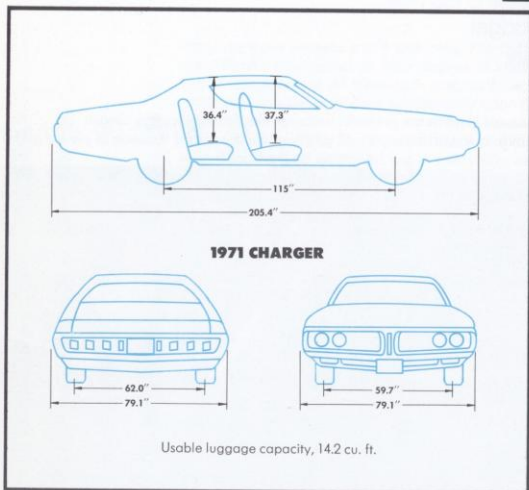

ENGINES

ENGINES	Coronet	Coronet Custom	Brougham & Crestwood	Charger Coupe	Charger	Charger 500	Super Bee & R/T	Special Edition
225 Six	Std. Six	Std. Six (Except 3-Seat Wagon)	N.A.	Std. Six	Std. Six	N.A.	N.A.	N.A.
318 V8	Std. V8	Std. V8	Std.	Std. V8	Std. V8	Std.	N.A.	Std.
383 V8 2-bbl.	Opt.	Opt.	Opt.	Opt.	Opt.	Opt.	N.A.	Opt.
383 V8 4-bbl.	Opt.	Opt.	Opt.	Opt.	Opt.	Opt.	Std., Super Bee; N.A., R/T	Opt.
440 V8 4-bbl.	N.A.	N.A.	N.A.	N.A.	N.A.	N.A.	Std., R/T; N.A., Super Bee	Opt.

Std.—Standard
Opt.—Optional
N.A.—Not Available
For a listing of special high-performance engines available on many Charger models, ask your Dodge Dealer for his special Performance catalog.

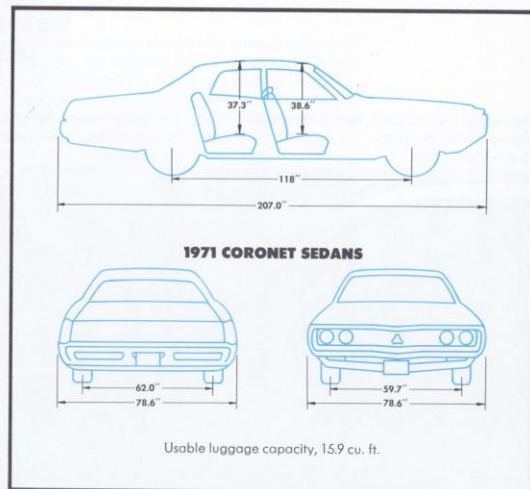

TRANSMISSIONS

There are four transmissions available on Charger/Coronet models.

- Three-speed manual (column-mounted shift), standard with 225 Six.
- Three-speed manual, fully synchronized.
(Column-mounted shift—standard with 318 V8 and 383 V8 4-bbl.)
(Floor-mounted shift—available with 383 V8 4-bbl. only. Standard on Super Bee.)
- Four-speed manual, fully synchronized (floor-mounted shift). N.A. with 225 Six or 2-bbl. V8's.
- TorqueFlite three-speed automatic optional all engines. Standard on R/T. The selector lever is column-mounted, except on bucket-seated models equipped with optional center console.

TIRES

All Charger/Coronet models are equipped with bias-belted tires:
Six-cylinder models (except wagons): E78 x 14
V8 models (except wagons): F78 x 14
All wagons: H78 x 14
V8 Coupe models: E78 x 14
R/T: G70 x 14 wide-tread, raised white letters
Super Bee: F70 x 14 wide-tread, white sidewalls

ELECTRICAL SYSTEM

Battery: 12-volt, 6-cell, 46-amp-hr (225 Six, 318 V8); 59-amp-hr (383 V8's); 70-amp-hr (440 V8)
Alternator: 37-amp, standard • Regulator: Transistorized

BRAKES

Hydraulic, servo-contact, self-energizing, with bonded linings. Parking brake is foot-operated, hand-released—mechanically actuating shoes on each rear wheel.

Brakes on all Charger/Coronet models are 10" x 2 1/2", front and rear, except R/T, Super Bee, and wagons which have 11" x 3", front—11/ x 2 1/2", rear.

CHARGER/CORONET OPTIONS AND EQUIPMENT

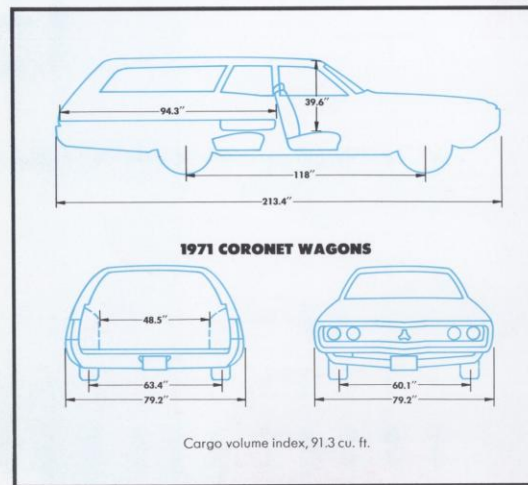

TRAILER-TOWING PACKAGE

STANDARD EQUIPMENT: Maximum Cooling System includes: high-capacity radiator, larger transmission oil cooler, large cooling fan—7 blades, fan shroud and hood seal • Heavy-duty axle—3.23 • Heavy-duty suspension, front and rear, with sway bar • Variable load turn-signal flasher • Heavy-duty stop-lamp switch.

REQUIRED EXTRA-COST ITEMS: V8 only (except 426 Hemi & 440 SixPack) • TorqueFlite transmission • Tires—G78 x 14 all (except Super Bee, R/T, & wagons); G70 x 14 on Super Bee & R/T; H78 x 14 on wagons • Power brakes • Disc brakes.

RECOMMENDED EXTRA-COST OPTIONAL EQUIPMENT: 383-cu.-in. V8, 2-bbl. • 383-cu.-in. V8, 4-bbl. • Sure Grip differential • Heavy-duty battery—70-amp • Power steering • Air conditioning • Automatic speed control.

OPTIONS

Charger/Coronet models offer a full range of options for your extra enjoyment. You can order items from a multiplex AM/FM stereo with cassette and recording microphone to an automatic speed-control system. Listed here are some of the more popular items available. For a more extensive listing, ask your Dealer.

• Airtemp air conditioning • Chromed steel road wheels • Luggage rack on rear deck lid (2-dr. models only) • Power brakes • Power steering • Power windows (N.A. Coupe)
• Vinyl roof • Radios: Several sound systems are available on all models. Ask your Dealer for details.

SPECIAL STATION WAGON OPTIONS: Luggage rack • Dual Action tailgate power window • Auto-Lock Dual Action tailgate (std., 3-seat wagons) • Rear window cleaning vane • Rear compartment lock.

1971 CHARGER/CORONET EXTERIOR COLORS



STANDARD SAFETY FEATURES

Dual Braking System
Turn signals (with lane change feature)
Padded instrument panel and sun visors
Master cylinder and parking brake warning light
Left, outside, rearview mirror
Safety-Action inside door handles
Front and rear seat belts
Breakaway front ashtray
Backup lights
Combination side marker lights and reflectors
Soft window knobs
Safety-Rim wheels
Energy-absorbing steering column and wheel

Windshield washers
2-speed electric windshield wipers; parallel-action blades with glare-reducing finish
Hazard Warning System (4-way flasher) warning light
Front shoulder belts
Security locks on front seatbacks (2-door models)
Padded front seatbacks
Nonoverride door locks, except driver's door
Head restraints
Anti-theft steering column lock
Rearview mirror with double-ball-joint mount
"Key-left-in-ignition" warning buzzer

All product illustrations and specifications are based on authorized information. Although all descriptions are believed correct at publication approval, accuracy cannot be guaranteed. Some of the equipment shown on product illustrations is optional, at extra cost. Dodge Division reserves the right to make changes from time to time, without notice or obligation, in prices, specifications, colors and materials, and to change or discontinue models.



On every Dodge you see, the low price is standard equipment.



Charger Coupe



Coronet



Charger



Coronet Custom



Charger 500



Coronet Brougham



Charger SE



Coronet (2-seat)



Charger Super Bee



Coronet Custom (2- and 3-seat)



Charger R/T



Coronet Crestwood (2- and 3-seat)

With a choice like this...
you can't afford not to be DODGE MATERIAL.

Dodge



CHRYSLER

1971 Dodge Charger/Coronet Catalog. 81-205-1038 8/70 Litho in U.S.A.